

REV	DESCRIPTION	BY	DATE

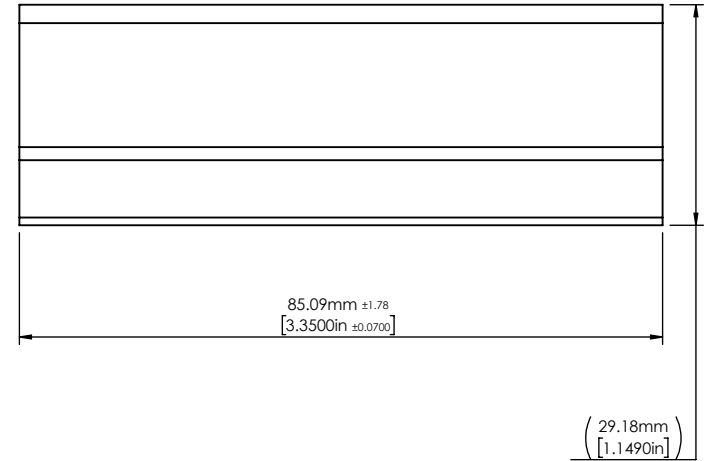
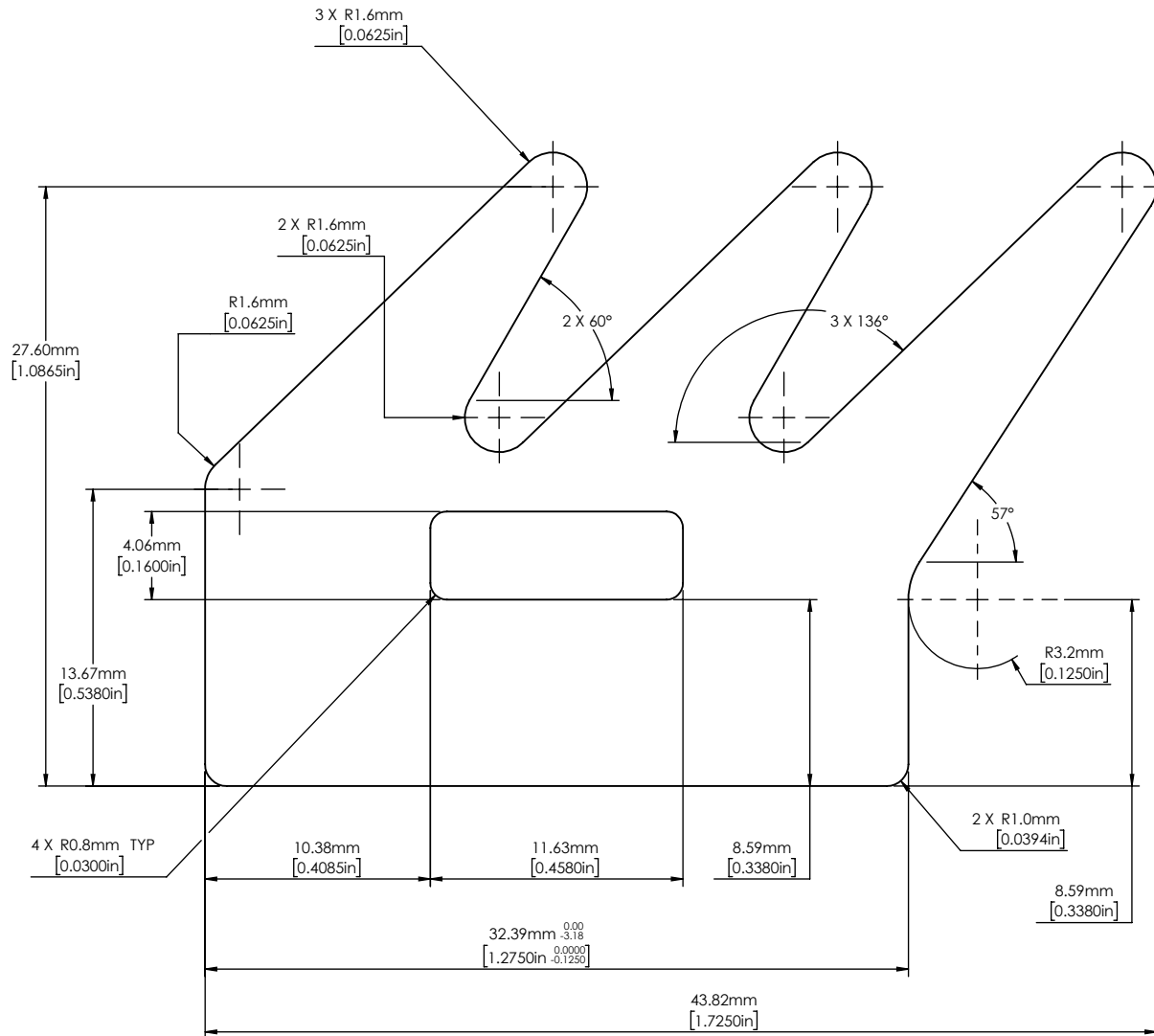
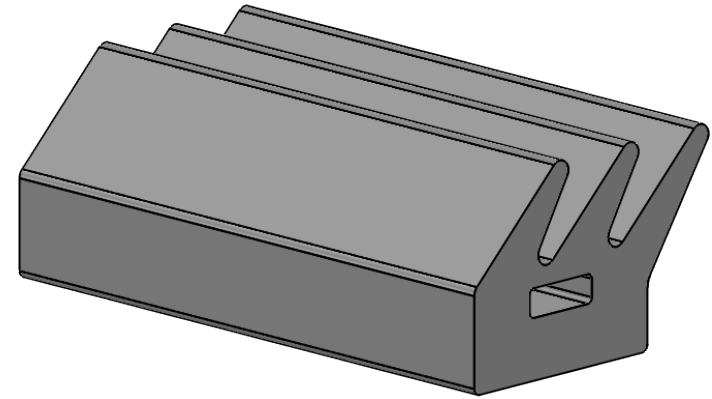

Houston Products, Inc.
 115 Lake Pine Road
 Mooresville, NC 28117
 (704) 564.0521
 info@houstonproductsinc.com
 www.houstonproductsinc.com

PROPRIETARY AND CONFIDENTIAL
 The information contained in this drawing is the sole property of HOUSTON PRODUCTS, INC. Any reproduction, in part or as a whole, without the written permission of HOUSTON PRODUCTS, INC. is prohibited.

Unless otherwise specified:
 Dimensions are in **MILLIMETERS**
Rubber Extrusion Tolerances
 Standard Tolerances Per Designation:
RMA E3 - "Commercial"
 Fractions ----- ±1/64"
 Angles ----- ±0.5°

MATERIAL & FINISH REMARKS
White EPDM
50 Duro, Shore A

DRAWN BY: **KS** **12.7.23**
ENGINEERING APPROVAL:

COMMENTS:

Title: 3-Finger Gripper, Standard		
Size A	Drawing Number	Rev.
Scale: NTS	Weight:	Sheet 1 of 1